

Name(s) _____

Game Room time slot: _____ to _____ (only for large groups)

Directions: Read the story below and fill in the blanks as you make your way around. Remember to be **respectful** and **responsible**. Take turns participating in the games, and be sure to ask an adult if you need help.

Welcome to the Iowa _____ of _____! When you leave here today, you should feel proud to live in _____.

Stained-glass Window

This window shows you all of the activities that Iowa students can participate in. Seven of the sports require the use of some sort of ball. Can you name the seven balls found in the window?

- 1. _____
- 2. _____
- 3. _____
- 4. _____
- 5. _____
- 6. _____
- 7. _____

Recess in a One-Room School

Find this mural in the very outer lobby. Sculpted in clay, this exhibit represents recess in Iowa's schools many years ago. At one time, there were 1,000 one-room schools in the state. Can you name three differences between this recess and yours?

- 1. _____
- 2. _____
- 3. _____

Media

Find the media exhibit and choose one or two people from your group to be a sports broadcaster. Press "Broadcaster Game," then choose an Iowa or Iowa State game to broadcast. Remember, please do not touch the microphone.

What game did you broadcast? _____ vs. _____

Tennis

Find the trivia game in the tennis exhibit. Then find the answer to the following question.

** If a ball falls on the line, is it considered IN or OUT? _____ **

Swimming

Find the swimming exhibit. Can you name (or draw) the four main swimming strokes? (Bonus question: Do you know which event requires a swimmer to swim all four of these strokes in one race? _____)

- 1. _____
- 2. _____
- 3. _____
- 4. _____

Baseball/Softball

Find the baseball that has a chunk cut out of it. Can you guess what each of the layers is made of? Label them below.

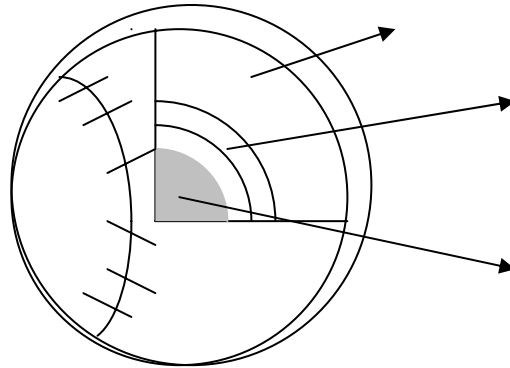

Virtual Basketball

Look for the green screen. Please play one-at-a-time otherwise the camera doesn't know what to do. Let your group play for five minutes or so, then move on to the next exhibit. Remember, you can always come back and play again later.

Football

Find the football exhibit and then look for the display case with the four football helmets. Can you put the helmets in chronological order by either drawing or describing them? Then in one or two sentences write why you think they've changed so much in the last 100+ years.

Why do you think the helmets have changed so much? _____

Choir

Find the choir exhibit right outside the main theater. You can listen to the All-State Choir sing two different songs. What are the names of those two songs?

1. _____
2. _____

Hall of Heroes

Can you find the Iowa gymnast who participated in the 2008 Olympics? What is her name?
_____ What year was she born? _____

Also in the Hall of Heroes – find the outstanding lowans with the initials R.R. What is his name?
_____ He served as Iowa's _____ for 14 years.

Orchestra/Band

Locate the orchestra/band exhibit. Back in this corner, you can record yourself singing or conduct an orchestra. Choose Choir Sing Along or Be the Conductor on the monitor. Rate your groups performance on a scale of 1 to 10. _____

This is where the scavenger hunt ends. If you have time, go back and visit exhibits that weren't on this scavenger hunt, or something you missed. But remember, *you must stay with your adult leader at all times*. Thank you!

THANK YOU FOR VISITING THE IOWA HALL OF PRIDE! COME BACK AND SEE US AGAIN.